



- **Portable USB Device**
- **On Board resources (200MHz processor, 64Mbytes RAM, 16Mbytes Flash, 256Mbytes NAND Flash)**
- **MIL-STD-1553B – Optional**
 - > IPC1553 – Next generation 1553 core
 - > 1 Dual Redundant MIL-STD-1553 Channel
 - > Each channel is independently programmable as either
 - > Bus Controller, Remote Terminal or Bus Monitor
 - > Complete message programmability
 - > Direct or Transformer Coupled Bus Interface
- **ARINC429 – Optional**
 - > IPC429 – Next generation 429 core
 - > 8 Transmit and 8 Receive Channels
 - > Configurable for High Speed (100 Kbps) or Low Speed (12.5Kbps/50Kbps)
- > **Upto 256 Label memory for each Receive channel**
- > **128 Word for Tx and Rx FIFOs for each Transmit and Receive channel**
- > **Asynchronous and Synchronous messaging**
- > **Programmable Interrupts**
- > **Programmable Refresh rates of 20ms to 200ms**
- > **Label selective trigger for Capture/Filtering and SDI filtering**
- **Optional 6 discrete inputs and 6 discrete outputs**
- **IRIG-B Time Code Input (Digital/Analog)**
- **IRIG-B Time Code Generator/Output (Digital)**
- **GPS Synchronization capability (optional)**
- **Software Driver Support for Windows 7 and Linux are available**

OVERVIEW

The AT-USB-MPAC family of products provides the highest level of performance and flexibility on various hardware interface architectures and custom platforms. Integrating MIL-STD-1553B, ARINC429 and Digital I/O channels, all in a single unit, it offers the ideal platform for test & evaluation of avionics systems and sub-systems. On board six discrete inputs and six discrete outputs, IRIG-B Time code Input/Output is also available. An onboard IRIG-B time code decoder and generator allow users to accurately synchronize single or multiple USB MPAC modules to a common time source.

SOFTWARE

The AT-USB-MPAC software includes Drivers and APIs. The module comes with a powerful set of library functions to access the entire MIL-STD-1553B and ARINC429 functionality. Source code is provided for samples, and detailed documentation. The drivers are designed in a modular fashion consisting of component functions & application functions. The user's test program can be developed with few calls to the driver, by using the set of Application functions provided. Driver and high-level API libraries for Windows 7, Linux are available.

PRODUCT SPECIFICATIONS

MIL-STD-1553B Interface

1553 Bus Controller (BC)

- 64K Words of memory per channel
- Automatic retries on alternate bus
- Inter-message gap times up to 65.5ms
- Programmable response timeout up to 130µs
- Major and minor frame content and timing
- Modify messages, data or setup while card is running
- Detects and reports 1553 errors
- Synchronize BC operation to external time source
- Programmable BC timeout values
- Flexible support for data streaming or bulk data transfer

1553 Remote Terminal (RT)

- 31 Remote terminal control
- Programmable response time and status word bits
- Programmable command illegalization
- Selectable interrupts upon multiple conditions
- Support for all 1553B mode codes
- Programmable Single Message or double buffering or circular buffering
- BUSY Bit programmable by sub address
- Alpha numeric message ID

AT-USB-MPAC

Multi Protocol Avionics Device

1553 Bus Monitor (MT)

- Word monitor per word basis
- Selective message monitor & time stamping
- Dynamic data update
- Message Periodicity
- Bus error status
- Bus load
- Unique Message identifier
- Record and Replay option
- Advanced Bus Error Detection to Isolate Bus Failures
- 100% data capture at full bus rates
- Programmable data logging to file
- Sequential record includes: command/status/data words, time-tag, errors, bus, and response time(s)

ARINC429 Interface

- Supports up to 16 ARINC429 channels
 - > 8 Transmit Channels
 - > 8 Receive Channels
- 128 Word deep FIFO on each channel
- Programmable Interrupts
- Built-in Fault Detection Circuitry
- Set parity per channel (odd/even/data)
- Sync output on all or selected messages
- Handles periodic and transfer protocols
- Message filters and schedules
- Data Rates: 12.5/50 Kbps in low speed and 100Kbps in high speed
- Standard input levels: ± 6.5 to ± 13 VDC
- Filtering: Label and/ or SDI
- Parity: Odd, even or none
- Error reporting: Parity
- Output levels: ± 10 VDC

Discrete I/O

- Optional Six Discrete Inputs & six Discrete Outputs

GPS Receiver (optional) for Synchronization

- GPS receiver on-board for synchronization
- Synchronization control through software
- Synchronization of on-board time tag counters with GPS time
- Separate GPS antenna provided along with the unit

Software Support

- Driver and high-level API libraries for Windows 7, Linux
- Sample applications provided

Physical

- Durable Enclosure with covers for connectors

Environmental

- Operating Temperature: 0°C to $+50^{\circ}\text{C}$
- Storage Temperature: -20°C to $+70^{\circ}\text{C}$

Warranty

- 1 year limited warranty

ORDERING INFORMATION

Hardware Selection

AT-USB-MPAC-1553-A429 – DIO - IRIG

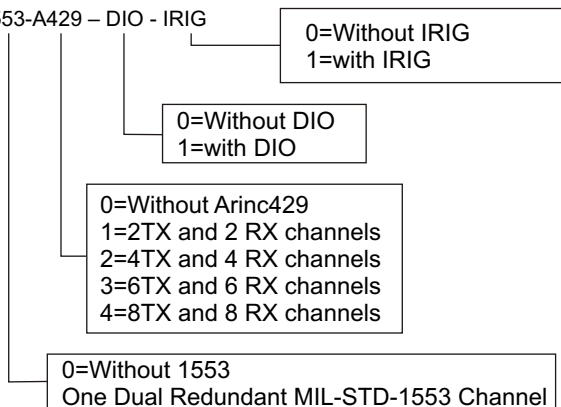

- Contact sales for support for other Operating Systems
- Contact sales for environmental options



ADTEC Electronics Inc.
144 Continente Ave , Suite #130
Brentwood, CA 94513, USA.
Ph : (408) 420 0646
www.adtecelectronics.com

Distributor/Reseller